

Eagle Air Compressor part breakdown sheet - Twin Tank Electric

Item	Description	TTDD318E	TT318E-DV	TT418E	TT518E
1	Compressor w/ Flywheel	SD-30	PV01A	PV02A	PT03A
2	Discharge Tube w/ Fittings	242044	TU-15-AL	TU-15-AL	TU-15-AL
3	Pressure Gauge (Regulator)	PT0160	PT0160	PT0160	PT0160
	Pressure Gauge (Tank)	PG200-2.5SI1/4	PG200-2.5SI1/4	PG200-2.5SI1/4	PG200-2.5R
4	Wiring Harness	N/A	12/3-42-TT50	12/3-42-TT15	12/3-42-TT15
5	Air Receiver	8TT35X5-B	8TT35X5-B	8TT35X5-B	8TT35X5-B
6	Drain Cock	DC1/4	DC1/4	DC1/4	DC1/4
7	V-Belt	N/A	A49	4L530	4L530
8	Belt Guard	N/A	BGC	BGC	BGC
9	Electric Motor	N/A	EM03.0-36-10SP-DV	EM05.0-36-10SPL	EM05.0-36-10
10	Regulator	R202-1/4	R202-1/4	R202-1/4	R202-1/4
11	Pilot Unloader/Check Valve	409004	NDC29-M	NDC29-M	NDC29-M
12	Pressure Switch	21UCBDB-CH	21UCBDB-CH	21UCBDB-CH	21UCBDB-CH
13	Pulley - Motor	N/A	MA33X5/8	MA38X5/8	MA38X7/8
14	Unloader Tubing w/ Fittings	N/A	TU1/4BLK	TU1/4BLK	TU1/4BLK
15	Safety Valve	PSV1/4-150	PSV1/4-150	PSV1/4-150	PSV1/4-150
16	Handle Grip	TT-GRIP (2)	TT-GRIP (2)	TT-GRIP (2)	TT-GRIP (2)
17	Vibration Damper	TT-FOOT (4)	TT-FOOT (4)	TT-FOOT (4)	TT-FOOT (4)
18	Pneumatic Wheel	TT-WHEEL	TT-WHEEL	TT-WHEEL	TT-WHEEL
19	Axle	WA1001	WA1001	WA1001	WA1001
20	Coupler	CPL-DUO	CPL-DUO	CPL-DUO	CPL-TRI
21	Power Cord w/ Plug	12/3-72-PT	12/3-72-PT	12/3-72-TTPE	12/3-72-TTP5
	Eagle Compressor Oil	EAOIL10	EAOIL10	EAOIL10	EAOIL10

MODELS

TTDD318E
 TT318E-DV
 TT418E
 TT518E

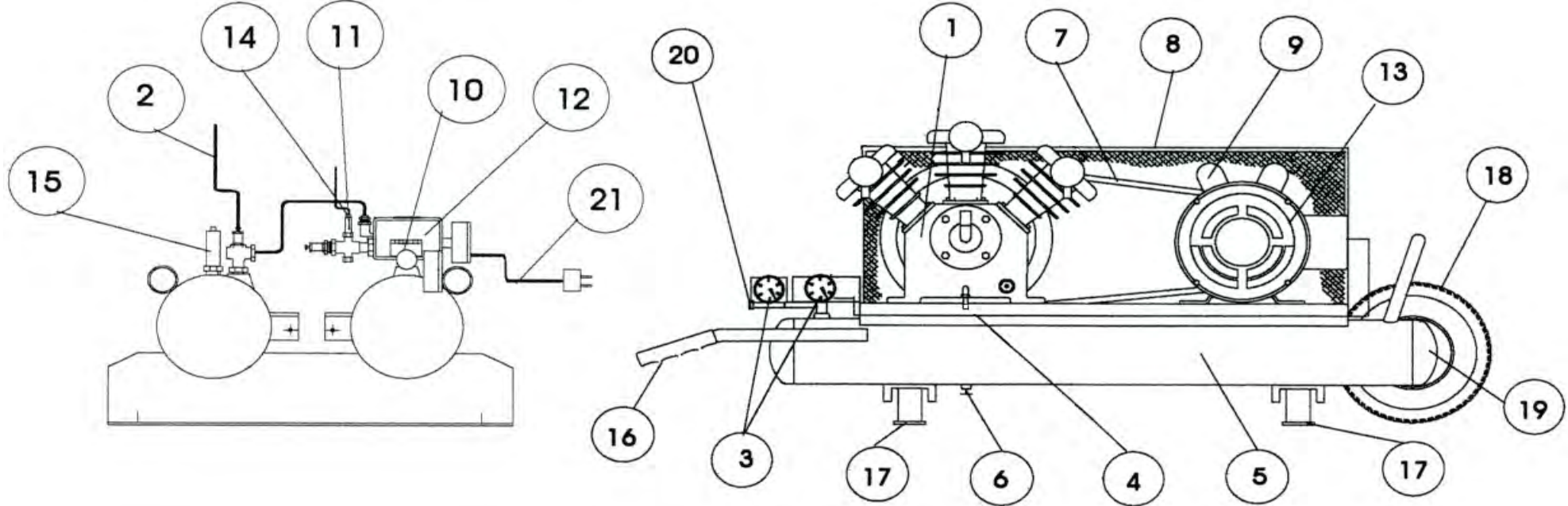

Eagle Air Compressor part breakdown sheet - TTDD318E

Item	Description	TTDD318E
1	Compressor w/ Flywheel	SD-30
2	Discharge Tube w/ Fittings	242044
3	Pressure Gauge (Regulator)	PT0160
	Pressure Gauge (Tank)	PG200-2.5SI1/4
4	Wiring Harness	N/A
5	Air Receiver	8TT35X5-B
6	Drain Cock	240-b
7	V-Belt	N/A
8	Belt Guard	N/A
9	Electric Motor	N/A
10	Regulator	R202-1/4
11	Pilot Unloader/Check Valve	409004
12	Pressure Switch	21UCBDB-CH
13	Pulley - Motor	N/A
14	Unloader Tubing w/ Fittings	N/A
15	Safety Valve	PSV1/4-150
16	Handle Grip	TT-GRIP (2)
17	Vibration Damper	TT-FOOT (4)
18	Pneumatic Wheel	TT-WHEEL
19	Axle	WA1001
20	Coupler	CPL-DUO
21	Power Cord w/ Plug	12/3-72-PT
	Eagle Compressor Oil	EAOIL10



Call 1-800-551-2406 for the Customer Service Department.

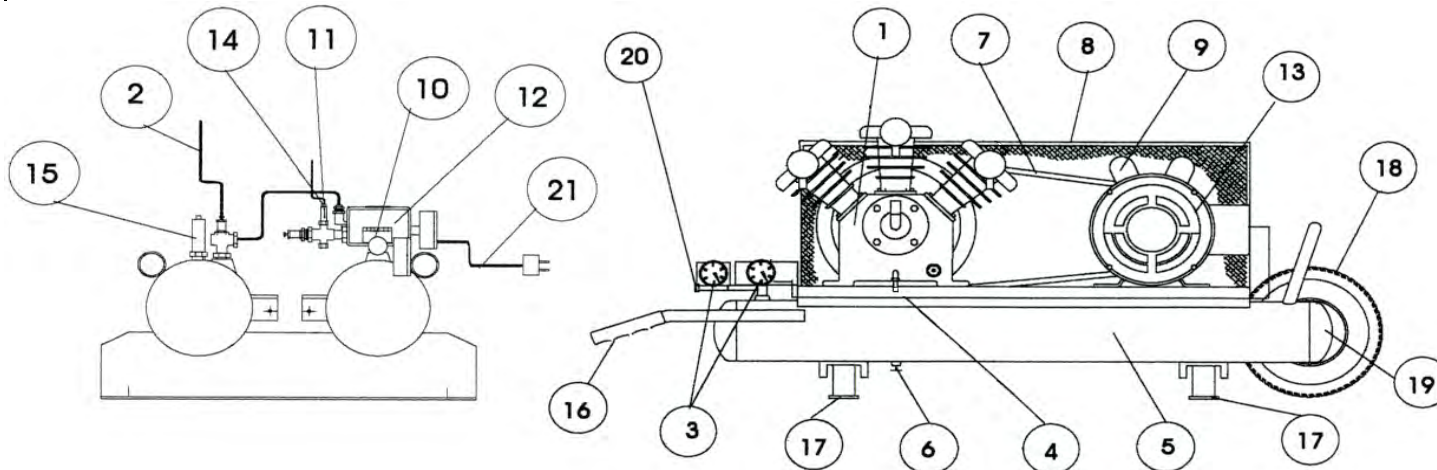

TTDD318E

Eagle Air Compressor part breakdown sheet - TT318E-DV

Item	Description	TT318E-DV
1	Compressor w/ Flywheel	PV01A
2	Discharge Tube w/ Fittings	TU-15-AL
3	Pressure Gauge (Regulator)	PT0160
	Pressure Gauge (Tank)	PG200-2.5SI1/4
4	Wiring Harness	12/3-42-TT50
5	Air Receiver	8TT35X5-B
6	Drain Cock	DC1/4
7	V-Belt	A49
8	Belt Guard	BGC
9	Electric Motor	EM03.0-36-10SP-DV
10	Regulator	R202-1/4
11	Pilot Unloader/Check Valve	NDC29-M
12	Pressure Switch	21UCBDB-CH
13	Pulley - Motor	MA33X5/8
14	Unloader Tubing w/ Fittings	TU1/4BLK
15	Safety Valve	PSV1/4-150
16	Handle Grip	TT-GRIP (2)
17	Vibration Damper	TT-FOOT (4)
18	Pneumatic Wheel	TT-WHEEL
19	Axle	WA1001
20	Coupler	CPL-DUO
21	Power Cord w/ Plug	12/3-72-PT
	Eagle Compressor Oil	EAOIL10



Call 1-800-551-2406 for the Customer Service Department.

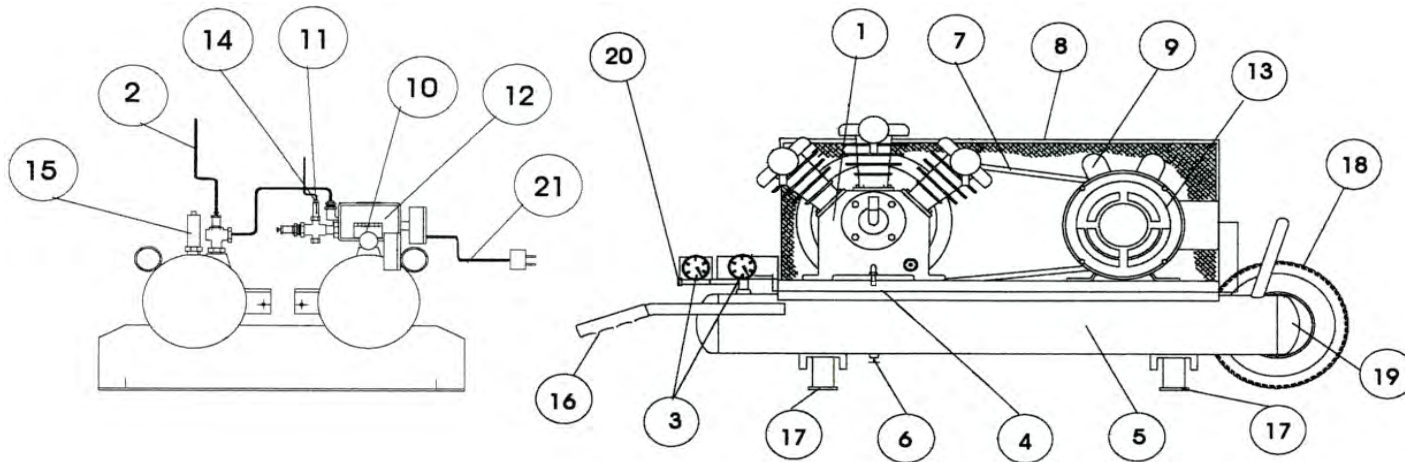

TT318E-DV

Eagle Air Compressor part breakdown sheet - TT518E

Item	Description	TT518E
1	Compressor w/ Flywheel	PT03A
2	Discharge Tube w/ Fittings	TU-15-AL
3	Pressure Gauge (Regulator)	PT0160
	Pressure Gauge (Tank)	PG200-2.5R
4	Wiring Harness	12/3-42-TT15
5	Air Receiver	8TT35X5-B
6	Drain Cock	DC1/4
7	V-Belt	4L530
8	Belt Guard	BGC
9	Electric Motor	EM05.0-36-10
10	Regulator	R202-1/4
11	Pilot Unloader/Check Valve	NDC29-M
12	Pressure Switch	21UCBDB-CH
13	Pulley - Motor	MA38X7/8
14	Unloader Tubing w/ Fittings	TU1/4BLK
15	Safety Valve	PSV1/4-150
16	Handle Grip	TT-GRIP (2)
17	Vibration Damper	TT-FOOT (4)
18	Pneumatic Wheel	TT-WHEEL
19	Axle	WA1001
20	Coupler	CPL-TRI
21	Power Cord w/ Plug	12/3-72-TTP5
	Eagle Compressor Oil	EAOIL10



Call 1-800-551-2406 for the Customer Service Department.

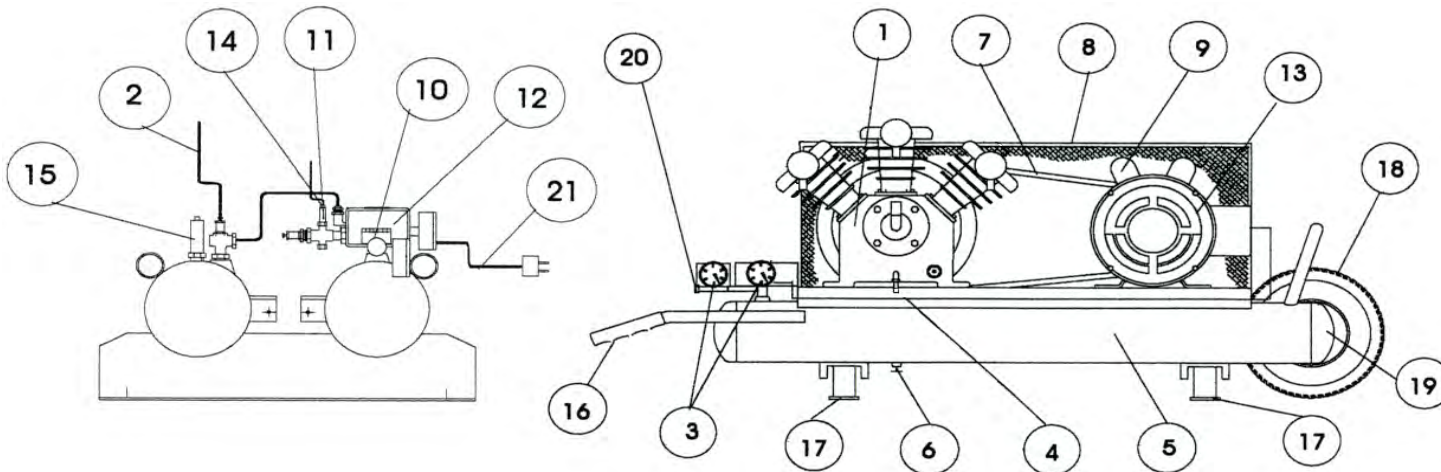

TT318E-DV